

BACK COUNTRY ACCESSORIES

Snap-On Tonneau Cover Installation Instructions



1. Wash Truck

If installing tonneau with a bedliner, refer to step 9.

2. Remove paper backing from all four rails

3. Set side rails onto truck

Thicker foam should face the rear of the vehicle.

4. Attach front and rear rails to side rails

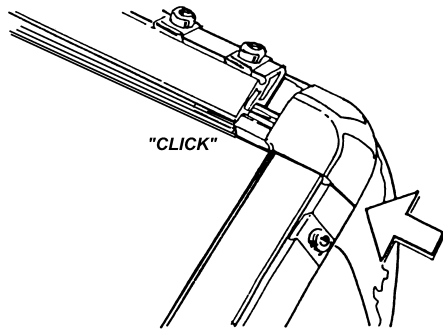

Slide corners into side rails until they snap into place.

Align frame from front to rear.

5. Install clamps

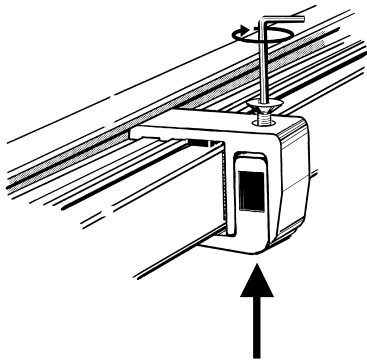

Place threaded insert into the "J" portion of the clamp, then thread screw through top of clamp and tighten.

Note: Some vehicles have two different lower clamps, the wider clamps should be placed at the ends of the rail. (2002 and later Dodge Ram: the widest clamp goes at the very front and the narrower clamps to the rear).

6. Install bows

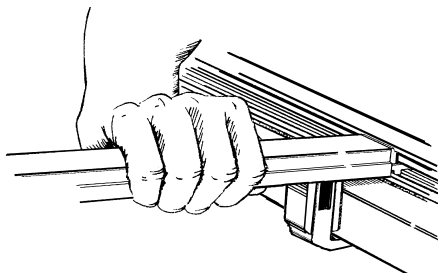

The bows nest **on top of** the clamps. Bows are numbered with bow #1 installing at the front, then bow #2 etc.

- Insert the rubber tip into the opening between the side rail and the top of the clamp (on the far side of the truck).
- Lift up the center of the bow, and insert the end nearest you.

Never fasten cover without all bows in place, severe weather could damage the cover or framework.

7. Fasten Cover

Fasten snaps in the sequence depicted below. The vinyl cover is permanently attached to the front rail primarily to prevent theft. Please take precautions when unfastening the cover. Fit of corners can be adjusted by moving the corner snap clips at the end of each rail.

Never drive with snaps un-fastened without the cover rolled and secured by the front tie straps - damage to fabric can occur.

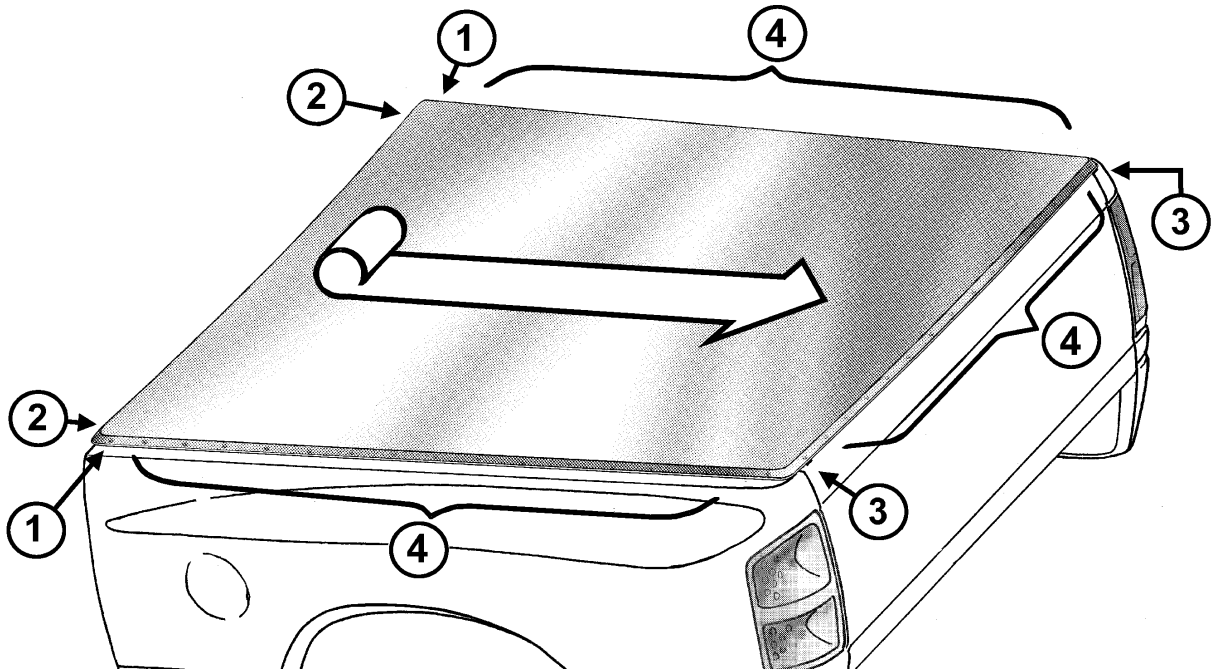

8. Warranty Card

Please fill out the enclosed warranty card and send it in within 30 days of purchase to activate your tonneau Cover warranty.

9. Bedliner installation:

We do not recommend installing this product with an over-the-rail bedliner.

To install with an under-the-rail bedliner, you may need additional rubber spacer blocks at the rear (part number DA-56). The bedliner may also need to be trimmed back at the front to allow for the front rail to seal properly.

Although clamps come pre-installed on the side rails, if clamps need to be relocated to install with another accessory, simply press down the tabs on either side of the clamp with a screwdriver and clamp will slide freely. Use caution, relocating clamps may reduce the effectiveness of the tonneau bows